

**THE 32<sup>ND</sup> EDITION** INTERNATIONAL EXHIBITION  
MUESTRA INTERNACIONAL



**X**TONE

# XTONE

XTONE takes its technological evolution to the maximum and showcases the most unique features of nature with innovative designs inspired by noble materials: stone, marble, wood and metal. Collections that exude balance and harmony in spaces.

XTONE lleva al máximo su evolución tecnológica y hace muestra de los rasgos más singulares de la naturaleza con innovadores diseños inspirados en los materiales nobles: piedra, mármol, madera y metal. Colecciones que desprenden equilibrio y armonía en los espacios.

*XTONE pousse au maximum son évolution technologique et met en valeur les caractéristiques les plus uniques de la nature avec des designs innovants inspirés de matériaux nobles: pierre, marbre, bois et métal. Des collections qui exaltent l'équilibre et l'harmonie des espaces.*



[www.xtone-surface.com](http://www.xtone-surface.com)

# THE TEXTURE

# REVOLUTION

comet | core | eclipse | lumen | orion | titan

*XTONE porcelain slabs push the boundaries of design, transforming innovative ideas into reality with advanced finished product solutions—driving an endless Revolution.*

*XTONE lleva los límites del diseño de sus placas más allá, transformando ideas innovadoras en realidad con soluciones avanzadas de producto acabado, impulsando una Revolución sin fin.*

*Les dalles en porcelaine XTONE repoussent les limites du design, transformant des idées innovantes en réalité grâce à des solutions avancées de produits finis, propulsant une Révolution sans fin.*

## CORE



Pressing porcelain together with decorative flakes to achieve a full-body effect.

Prensado del porcelánico junto a escamas decorativas para conseguir un efecto todo masa.

*Pressage de la porcelaine avec des éclats décoratifs pour obtenir un effet pleine masse.*

## COMET



A radiant effect produced by shimmering particles of varying intensity, depending on the angle from which the surface is viewed.

Partículas brillantes de diferente intensidad según el ángulo en el que se observa la superficie.

*Particules brillantes d'intensité variable selon l'angle d'observation de la surface.*

## ECLIPSE



Decorative selection with different particles to achieve various volumetric effects.

Selección decorativa con diferentes partículas para conseguir varios efectos de volumen.

*Sélection décorative avec différentes particules pour obtenir divers effets de volume.*

## IRITECH

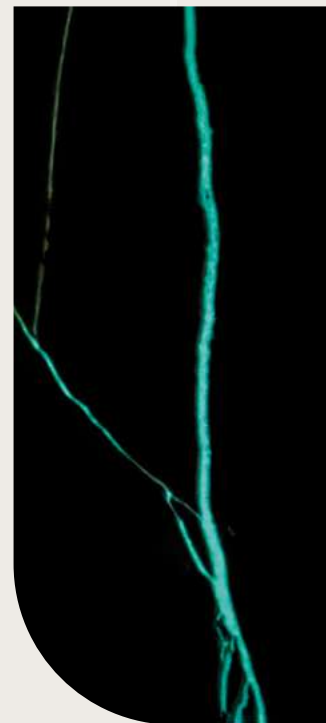

Smart luminescence that absorbs light and projects it in the dark.

Luminiscencia inteligente que absorbe la luz y la proyecta en la oscuridad.

*Luminescence intelligente qui absorbe la lumière et la projette dans l'obscurité.*

## LUMEN



Decorative reliefs in specifically chosen areas of the design.

Relieves decorativos en zonas seleccionadas del diseño.

*Reliefs décoratifs sur des zones sélectionnées du design.*

## ORION



Continuity of the veining inside the piece, giving it structural integrity.

Continuidad del veteado en el interior de la pieza, dotando a ésta de integridad.

*Continuité du veinage à l'intérieur de la pièce, lui conférant intégrité et cohérence.*

## TITAN



Surface design with metallic nuances.

Diseño superficial con matices metálicos.

*Design de surface avec des nuances métalliques.*

NEW

# COLLECTIONS



Antique Gold  
6

Aurora Noir  
10

Botanique  
14

Camouflage  
18

Ceppo Carabelas  
22



Mallorca Caliza  
26

Negresco  
30

Statuario Venato  
34

NEW

## FINISH



Astana Grey Nature  
39



Calacatta Viola Nature  
40

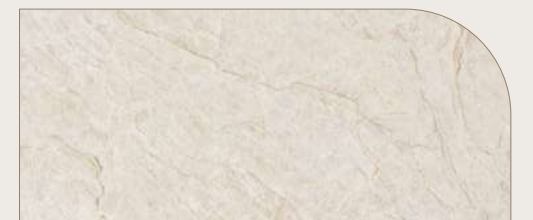

Taj Mahal Nature  
41

ANTIQUE GOLD LAPPATO 160X320

PREMIUM  
*Series*

*Antique  
Gold*



**THICKNESS**

6MM 12MM  
1/4" 1/2"

**GV LAPPATO**

6MM 12MM  
GV1056 GV1063

**SIZES**

160x320cm  
63"x126"  
160x160cm  
63"x63"

**FINISH**

LAPPATO

**COUNTERTOP 12MM**

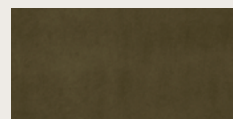

**DESIGN VARIETY 6MM**

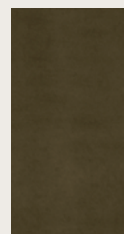

**FLOOR TILES 6MM**

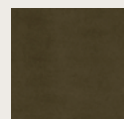

ANTIQUÉ GOLD LAPPATO 160X320

*ANTIQUÉ GOLD evokes the grandeur of noble metal transformed by the passage of time, reinterpreting aged gold through a sophisticated and deeply contemporary aesthetic. Its surface conveys the beauty of experience: luminous golden nuances, warm reflections, and subtle variations that recall historic pieces polished by the years, where every mark tells a story.*

*ANTIQUÉ GOLD evoca la grandeza del metal noble transformado por el paso del tiempo, reinterpretando el oro envejecido con una estética sofisticada y profundamente contemporánea. Su superficie transmite la belleza de lo vivido; matices dorados brillantes, reflejos cálidos y variaciones sutiles que recuerdan a piezas históricas pulidas por los años, donde cada marca cuenta una historia.*

*ANTIQUÉ GOLD évoque la grandeur du métal noble façonné par le passage du temps, réinterprétant l'or vieilli à travers une esthétique sophistiquée et profondément contemporaine. Sa surface révèle la beauté du vécu : des nuances dorées lumineuses, des reflets chaleureux et de subtiles variations qui rappellent des pièces historiques polies par les années, où chaque marque raconte une histoire.*

PREMIUM  
*Series*

*Aurora  
Noir*

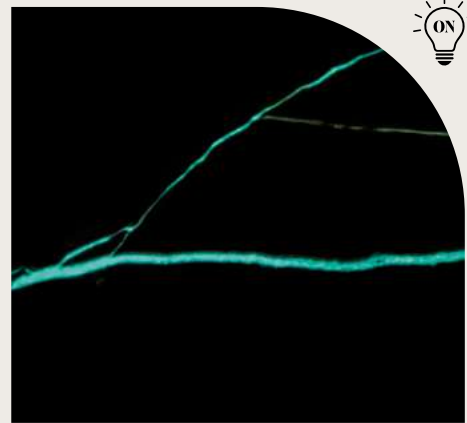

**THICKNESS**

6MM 12MM  
1/4" 1/2"

**GV POLISHED**

6MM 12MM  
GV1056 GV1063

**SIZES**

160x320cm  
63"x126"

**FINISH**

POLISHED

**COUNTERTOP 12MM**

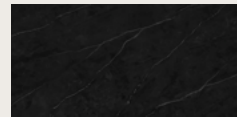

**DESIGN VARIETY 6MM**

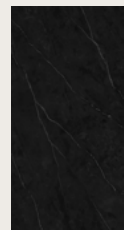

IRITECH

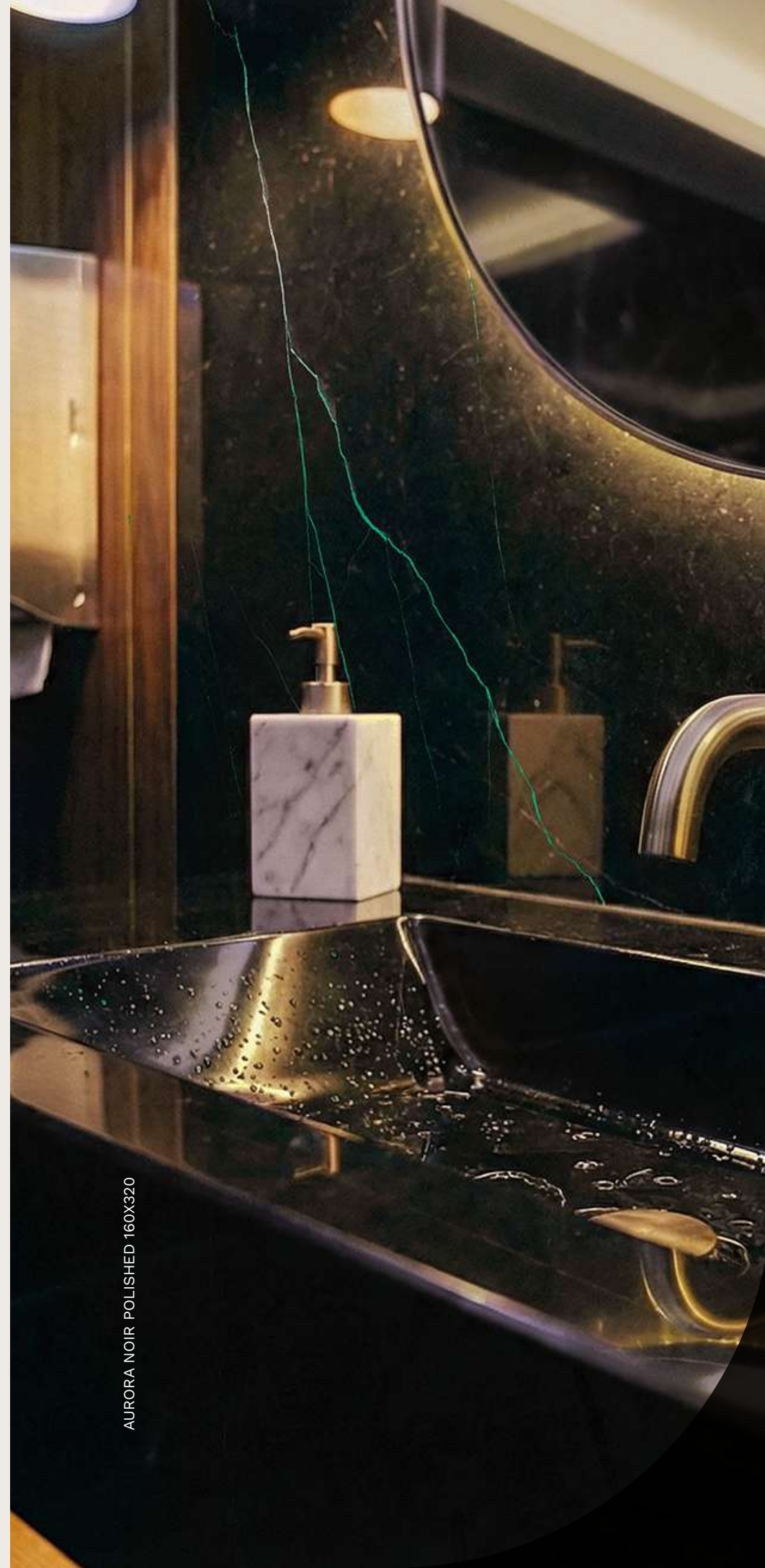

AURORA NOIR is born from the deepest night, revealing a dark surface polished to a mirror-like finish, crossed by white veining that seems to take on a life of its own. Under light, its elegance is restrained and magnetic; in darkness, those veins softly glow, emerging like an ethereal phenomenon that slowly fades away, reminiscent of the hypnotic movement of an aurora borealis in the silent night. The polished finish enhances reflections and depth, creating a unique sensory interplay between light, shadow, and time—ideal for spaces seeking to surprise through sophistication and transform material into an almost poetic experience.

AURORA NOIR nace de la noche más profunda, revelando una superficie oscura y pulida como un espejo, atravesada por vetas blancas que parecen cobrar vida propia. Bajo la luz, su elegancia es sobria y magnética; en la oscuridad, esas vetas se iluminan suavemente, emergiendo como un fenómeno etéreo que se desvanece poco a poco, evocando el movimiento hipnótico de una aurora boreal en pleno silencio nocturno. El acabado pulido intensifica los reflejos y la profundidad del material, creando un juego sensorial único entre luz, sombra y tiempo, ideal para espacios que buscan sorprender desde la sofisticación y convertir la materia en una experiencia casi poética.

AURORA NOIR naît de la nuit la plus profonde, révélant une surface sombre au poli miroir, traversée de veines blanches qui semblent s'animer. Sous la lumière, son élégance est sobre et magnétique; dans l'obscurité, ces veines s'illuminent délicatement, apparaissant comme un phénomène éthéré qui se dissipe lentement, évoquant le mouvement hypnotique d'une aurore boréale dans le silence nocturne. Le fini poli intensifie les reflets et la profondeur, créant un jeu sensoriel unique entre lumière, ombre et temps, idéal pour des espaces en quête de surprise, de sophistication et d'une matière presque poétique.

AURORA NOIR POLISHED 160X320

BOTANIQUE PRUNE GLOSSY 130X270  
MALLOPCA CALIZA TEXTURE 160X320  
MALLOPCA CALIZA ANTI-SLIP 160X160



*Botanique*

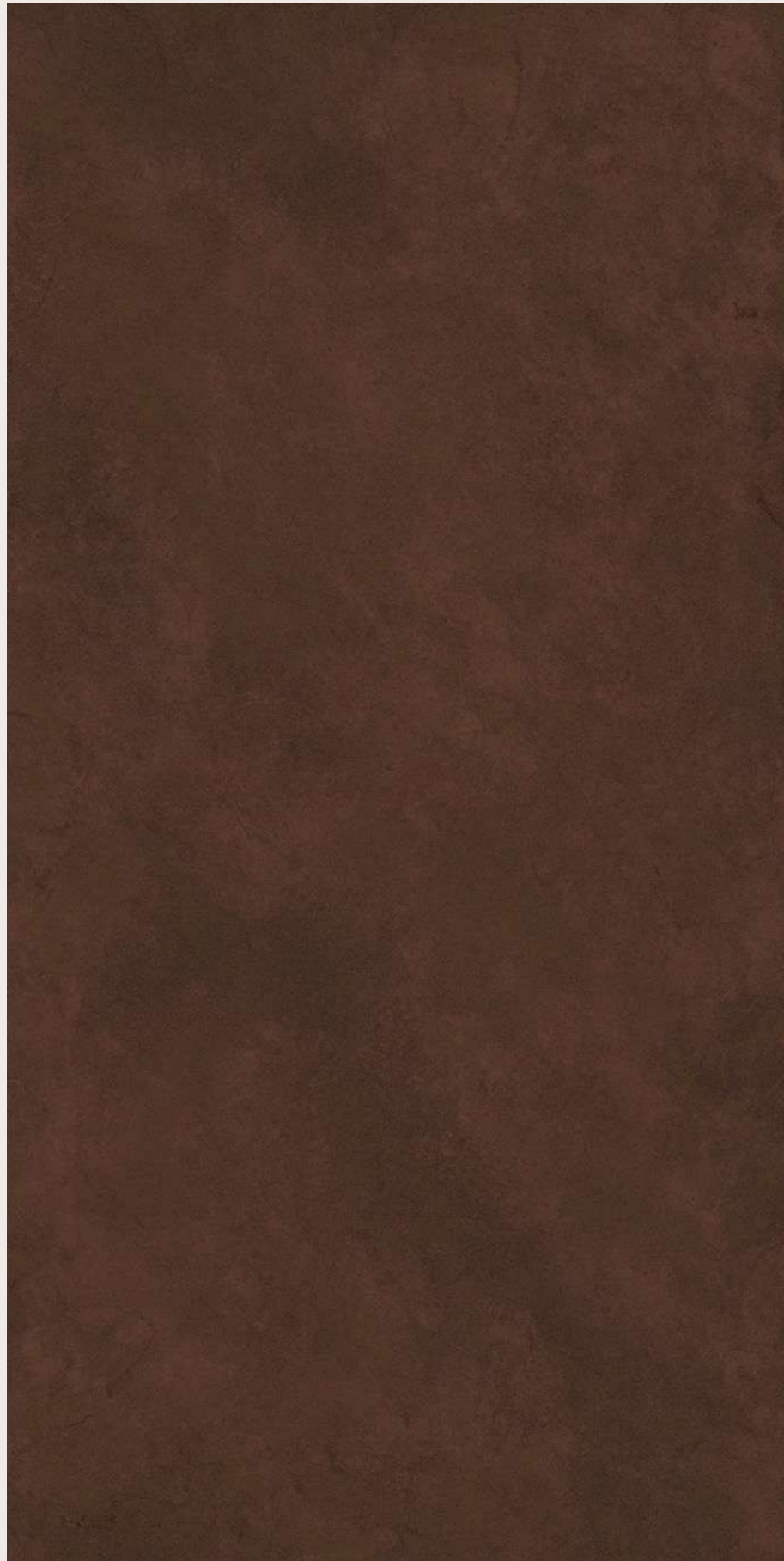

**THICKNESS**

6MM 12MM  
1/4" 1/2"

**GV GLOSSY**

6MM 12MM  
GV1054 GV1059

**SIZES**

130x270cm  
51"x106"

**FINISH**

GLOSSY

**COUNTERTOP 12MM**

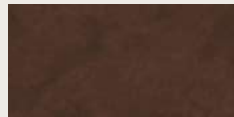

**DESIGN VARIETY 6MM**



**THICKNESS**

6MM 12MM  
1/4" 1/2"

**GV GLOSSY**

6MM 12MM  
GV1054 GV1059

**SIZES**

130x270cm  
51"x106"

**FINISH**

GLOSSY

**COUNTERTOP 12MM**

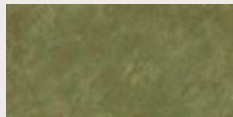

**DESIGN VARIETY 6MM**

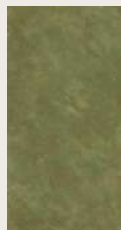



CAMOUFLAGE TEXTURE 160X320  
ELE NATURE 160X160

# *Camouflage*



**THICKNESS**

6MM 12MM  
1/4" 1/2"



**GV TEXTURE**

6MM 12MM  
GV1052 GV1058

**SIZES**

160x320cm  
63"x126"  
160x160cm (6mm)  
63"x63"

**FINISH**

TEXTURE

**COUNTERTOP 12MM**



**BOOKMATCH**

**DESIGN VARIETY 6MM**



**I320 - INFINITE CONTINUITY LONG SIDE**

**FLOOR TILES 6MM**



CORE | ECLIPSE

*Camouflage captures the essence of unique stones, with flowing veins and harmonious contrasts that bring character and sophistication to any space.*

*Camouflage captura la esencia de piedras únicas, con vetas fluidas y contrastes armónicos que aportan carácter y sofisticación a cualquier espacio.*

*Camouflage capture l'essence de pierres uniques, avec des veines fluides et des contrastes harmonieux qui apportent caractère et sophistication à tout espace.*



CAMOUFLAGE TEXTURE 160X320

*Ceppo  
Carabelas*



THICKNESS	
6MM 1/4"	12MM 1/2"



GV TEXTURE		
6MM GV1051	12MM GV1058	LINES GV1052

SIZES
160x320cm 63"x126"
160x160cm (6mm) 63"x63"

FINISH
TEXTURE



BOOKMATCH

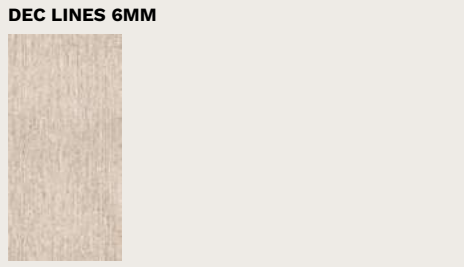

1320 - INFINITE CONTINUITY LONG SIDE

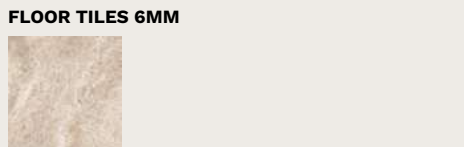

The surface of this natural stone showcases warm beige tones accented by subtle veining, creating a sense of depth and gentle visual movement. Its refined texture, reminiscent of travertine or limestone, exudes serene elegance and understated sophistication. Perfect for elevating high-end spaces, this stone delivers timeless luxury, transforming any interior into an oasis of warmth and sophistication.

La superficie de esta piedra natural exhibe cálidos tonos beige surcados por vetas sutiles, aportando profundidad y un suave dinamismo visual. Su textura refinada, que recuerda al travertino o a la piedra caliza, evoca una sensación de serenidad y elegancia discreta. Perfecta para realzar espacios de diseño sofisticado, esta piedra irradia un lujo atemporal y transforma cualquier ambiente en un oasis de calidez y sofisticación.

La surface de cette pierre naturelle révèle des teintes beiges chaleureuses parcourues de veines subtiles, conférant de la profondeur et un mouvement visuel délicat. Sa texture raffinée, rappelant le travertin ou le calcaire, évoque une sensation de sérénité et d'élégance discrète. Idéale pour sublimer des espaces au design sophistiqué, cette pierre offre un luxe intemporel qui métamorphose chaque intérieur en une oasis de chaleur et de sophistication.

MALLORCA CALIZA TEXTURE 160X320  
MALLORCA CALIZA ANTI-SLIP 160X160

*Mallorca*



**THICKNESS**

6MM 1/4"	10MM 3/8"	12MM 1/2"
-------------	--------------	--------------



**GV TEXTURE / STRIPED / ANTI-SLIP**

6MM GV1050	10MM GV1055	12MM GV1055	STRIPED GV1052
---------------	----------------	----------------	-------------------

**SIZES**  
 160x320cm  
 63"x126"  
 160x160cm (6mm)  
 63"x63"  
 160x160cm (10mm) ANTI-SLIP  
 63"x63"

**FINISH**  
 TEXTURE  
 ANTI-SLIP



**I320 - INFINITE CONTINUITY LONG SIDE**

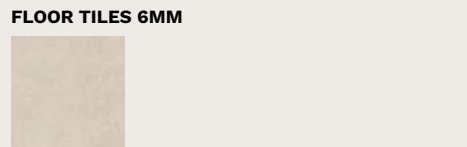

*The serene essence of Mallorca Caliza is inspired by the purity and brightness of Mediterranean stones. Its soft texture and light tones convey calmness and natural beauty, creating spaces that exude openness and balance. This high-end ceramic faithfully recreates the timeless elegance of limestone, offering versatility and distinction in both contemporary and classic settings.*

*La esencia serena de Mallorca Caliza se inspira en la pureza y luminosidad de las piedras mediterráneas. Su textura suave y sus tonos claros transmiten calma y naturalidad, creando espacios que respiran amplitud y equilibrio. Esta cerámica de alta gama recrea con fidelidad la elegancia atemporal de la piedra caliza, aportando versatilidad y distinción tanto en entornos contemporáneos como clásicos.*

*L'essence sereine de Mallorca Caliza s'inspire de la pureté et de la luminosité des pierres méditerranéennes. Sa texture douce et ses tons clairs transmettent calme et naturel, créant des espaces qui respirent l'amplitude et l'équilibre. Ce carrelage haut de gamme recrée avec fidélité l'élégance intemporelle du calcaire, offrant polyvalence et distinction dans les environnements contemporains comme classiques.*

MALLORCA CALIZA TEXTURE 160X320  
 MALLORCA CALIZA ANTI-SLIP 160X160



NEGRESKO TEXTURE 160X320  
NEGRESKO TEXTURE 160X160

# Negresco



**THICKNESS**

6MM 12MM  
1/4" 1/2"



**GV TEXTURE**

6MM 12MM  
GV1052 GV1058

**SIZES**

160x320cm  
63"x126"  
160x160cm (6mm)  
63"x63"

**FINISH**

TEXTURE

**COUNTERTOP 12MM**

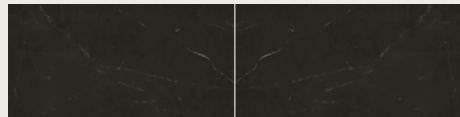

**BOOKMATCH**

**DESIGN VARIETY 6MM**

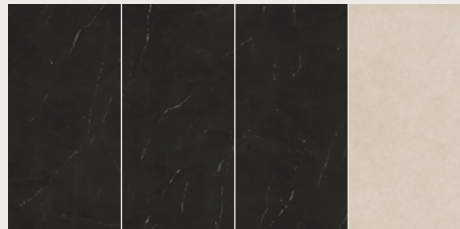

**C320 - CONTINUITY LONG SIDE**

**FLOOR TILES 6MM**

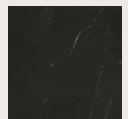

LUMEN

*Deep black stone with delicate white veins flowing across its surface like flashes of light. Its elegant contrast conveys strength and sophistication, perfect for creating contemporary spaces with an exclusive character.*

*Piedra negra de tonos intensos con finas vetas blancas que recorren su superficie como destellos de luz. Su contraste elegante transmite fuerza y sofisticación, ideal para crear espacios contemporáneos de carácter exclusivo.*

*Pierre noire aux veines blanches délicates qui traversent sa surface tels des éclairs de lumière. Son contraste élégant exprime force et sophistication, idéale pour créer des espaces contemporains au caractère exclusif.*



NEGRESKO TEXTURE 160X320  
TADELAKT SAND TEXTURE 160X320  
NEDA NATURE 160X160



# *Statuario Venato*



**THICKNESS**

6MM 1/4"	12MM 1/2"	20MM 3/4"
-------------	--------------	--------------



**GV NATURE**

6MM GV1051	12MM GV1057	20MM GV1062
---------------	----------------	----------------

**GV POLISHED**

6MM GV1053	12MM GV1059	20MM GV1064
---------------	----------------	----------------

**SIZES**

160x320cm  
63"x126"

160x160cm (6mm)  
63"x63"

**FINISH**

NATURE  
POLISHED

**COUNTERTOP 12MM**



**I320 - INFINITE CONTINUITY SHORT SIDE**

**DESIGN VARIETY 6MM**



**I320 - INFINITE CONTINUITY LONG SIDE**

**FLOOR TILES 6MM**



*This marble of immaculate beauty, quarried in the Carrara region and used since Roman times, is considered the undeniable choice for spaces where luminosity, elegance, and prestige are sought in equal measure. Its intense white background, crossed by broad, deep-grey veining, makes it the quintessential symbol of the Apuan Alps.*

*Este mármol de belleza impoluta, extraído de la zona de Carrara y utilizado desde la época romana, es considerado la opción innegable para aquellos espacios donde se busca una dotación de luz, a la par que elegancia y prestigio. Su blanco intenso bañado por extensas vetas de un gris profundo lo convierten en el símbolo por antonomasia de los Alpes Apuanos.*

*Ce marbre à la beauté immaculée, extrait de la région de Carrare et utilisé depuis l'époque romaine, est considéré comme le choix incontestable pour les espaces où l'on recherche à la fois luminosité, élégance et prestige. Son blanc intense, parcouru de larges veines d'un gris profond, en fait le symbole par excellence des Alpes apuanes.*



STATUARIO VENATO NATURE 160X320  
MALLORCA CALIZA TEXTURE 160X160

# NEW FINISH



ASTANA GREY NATURE 160X320  
ELE NATURE 160X160



**THICKNESS**

6MM 12MM  
1/4" 1/2"

**GV NATURE**

6MM 12MM  
GV1051 GV1058

**GV POLISHED**

6MM 12MM  
GV1053 GV1059

**SIZES**

160x320cm  
63"x126"  
160x160cm\*  
63"x63"

**FINISH**

NATURE  
POLISHED

**COUNTERTOP 12MM**



**BOOKMATCH**

**DESIGN VARIETY 6MM**



**I320 - INFINITE CONTINUITY LONG SIDE**

**FLOOR TILES 6MM**



ASTANA GREY

LUMEN

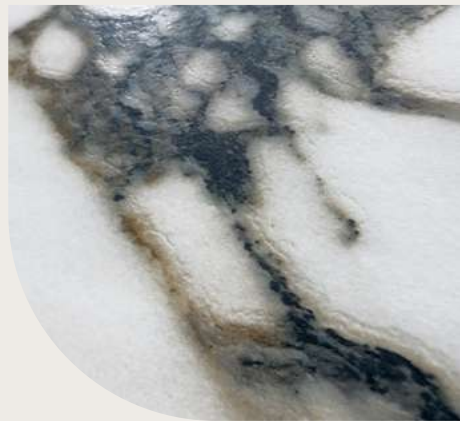

**THICKNESS**

6MM 12MM  
1/4" 1/2"

**GV POLISHED**

6MM 12MM  
GV1053 GV1059

**GV NATURE**

6MM 12MM  
GV1051 GV1057

**SIZES**

160x320cm  
63"x126"  
160x160cm (6mm)  
63"x63"

**FINISH**

POLISHED  
NATURE

**COUNTERTOP 12MM**



**1160 - INFINITE CONTINUITY SHORT SIDE**

**DESIGN VARIETY 6MM**



**1320 - INFINITE CONTINUITY LONG SIDE**

**FLOOR TILES 6MM**



LUMEN



**THICKNESS**

6MM 12MM 20MM  
1/4" 1/2" 3/4"

**GV NATURE**

6MM 12MM  
GV1051 GV1057

**GV POLISHED**

6MM 12MM  
GV1053 GV1059

**GV SILK**

6MM 12MM 20MM  
GV1053 GV1059 GV1063

**SIZES**

160x320cm  
63"x126"  
160x160cm\*  
63"x63"

**FINISH**

NATURE  
POLISHED  
SILK

**COUNTERTOP 12MM**

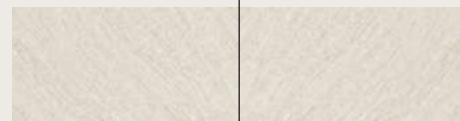

**BOOKMATCH**

**DESIGN VARIETY 6MM**



**1320 - INFINITE CONTINUITY LONG SIDE**

**FLOOR TILES 6MM**



LUMEN

# TABLES

## AUREA

	Height   Altura   Hauteur 73cm / 29"	NATURE	POLISHED		Height   Altura   Hauteur 105cm / 41,3"	NATURE	POLISHED	
☐	120x240 cm / 47,2" x 94,5"	G1952	G1953	☐	D 70 cm / D 27,6"	G1913	G1913	
	D 150 cm / D 59,1"	G1971	G1971		☑	D 70 cm / D 27,6"	G1915	G1915
	D 120 cm / D 47,2"	G1970	G1970					
☑	120x240 cm / 47,2" x 94,5"	G1953	G1930	☐ Straight edge   Canto recto   Chant droit ☑ Mitred edge   Canto ingletado   Chant aile d'avion				
	D 150 cm / D 59,1"	G1973	G1973					
	D 120 cm / D 47,2"	G1972	G1972					

☐ Straight edge | Canto recto | Chant droit ☑ Mitred edge | Canto ingletado | Chant aile d'avion



MESA AUREA - VENDOME NATURE 120X240X73



MESA FOCUS - BRECCIA IMPERIALE TEXTURE 90X200X73

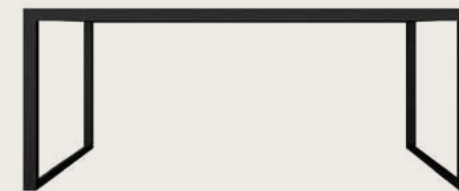

Height   Altura   Hauteur 73cm / 29"	NATURE	POLISHED
90x160 cm / 35,4" x 63"	G1930	G1931
90x180 cm / 35,4" x 70,9"		
90x200 / 35,4" x 78,7"		

# TABLES

## FOCUS

# BATH XBR

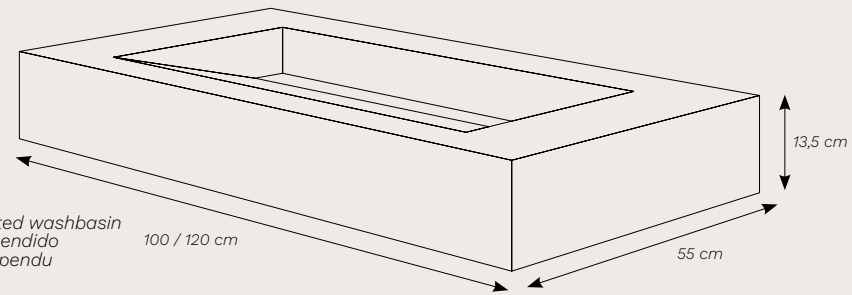

Wall-mounted washbasin  
Lavabo suspendido  
Vasque suspendu

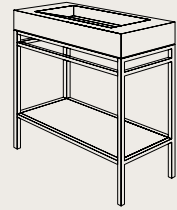

Floor-standing furniture with shelf  
Mueble a suelo con balda  
Meuble au sol avec étagère

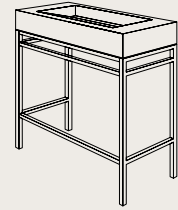

Floor-standing furniture without shelf  
Mueble a suelo sin balda  
Meuble au sol sans étagère

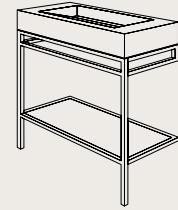

Wall-mounted furniture with shelf  
Mueble a pared con balda  
Meuble mural avec étagère

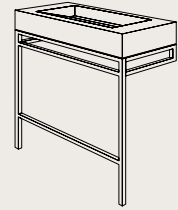

Wall-mounted furniture without shelf  
Mueble a pared sin balda  
Meuble mural sans étagère

\*Furniture height / Altura del mueble / Hauteur du meuble 76 cm

	Lavabo/Basin			Lavabo/Basin			Lavabo/Basin			Lavabo/Basin		
	Estructura Structure	Nature	Polished	Estructura Structure	Nature	Polished	Estructura Structure	Nature	Polished	Estructura Structure	Nature	Polished
100x55 cm / 39,4" x 21,7"	G1802	G1952	G1953	G1801	G1952	G1953	G1801	G1952	G1953	G1800	G1952	G1953
120x55 cm / 47,2" x 21,7"												
Baldas/Shelves/Étagères												
95,6x50,6 cm / 37,6" x 19,9"		G1800	G1801		G1800	G1801		G1800	G1801		G1800	G1801
115,6x50,6 cm / 45,5" x 19,9"												

# BATH XBU

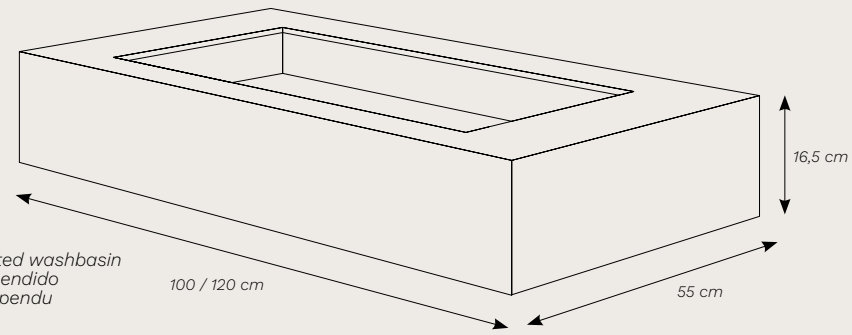

Wall-mounted washbasin  
Lavabo suspendido  
Vasque suspendu

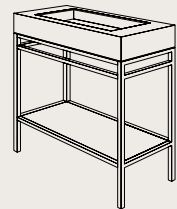

Floor-standing furniture with shelf  
Mueble a suelo con balda  
Meuble au sol avec étagère

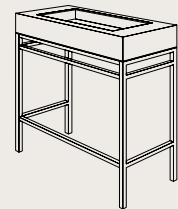

Floor-standing furniture without shelf  
Mueble a suelo sin balda  
Meuble au sol sans étagère

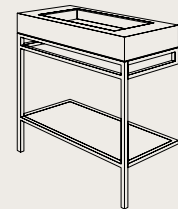

Wall-mounted furniture with shelf  
Mueble a pared con balda  
Meuble mural avec étagère

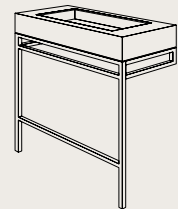

Wall-mounted furniture without shelf  
Mueble a pared sin balda  
Meuble mural sans étagère





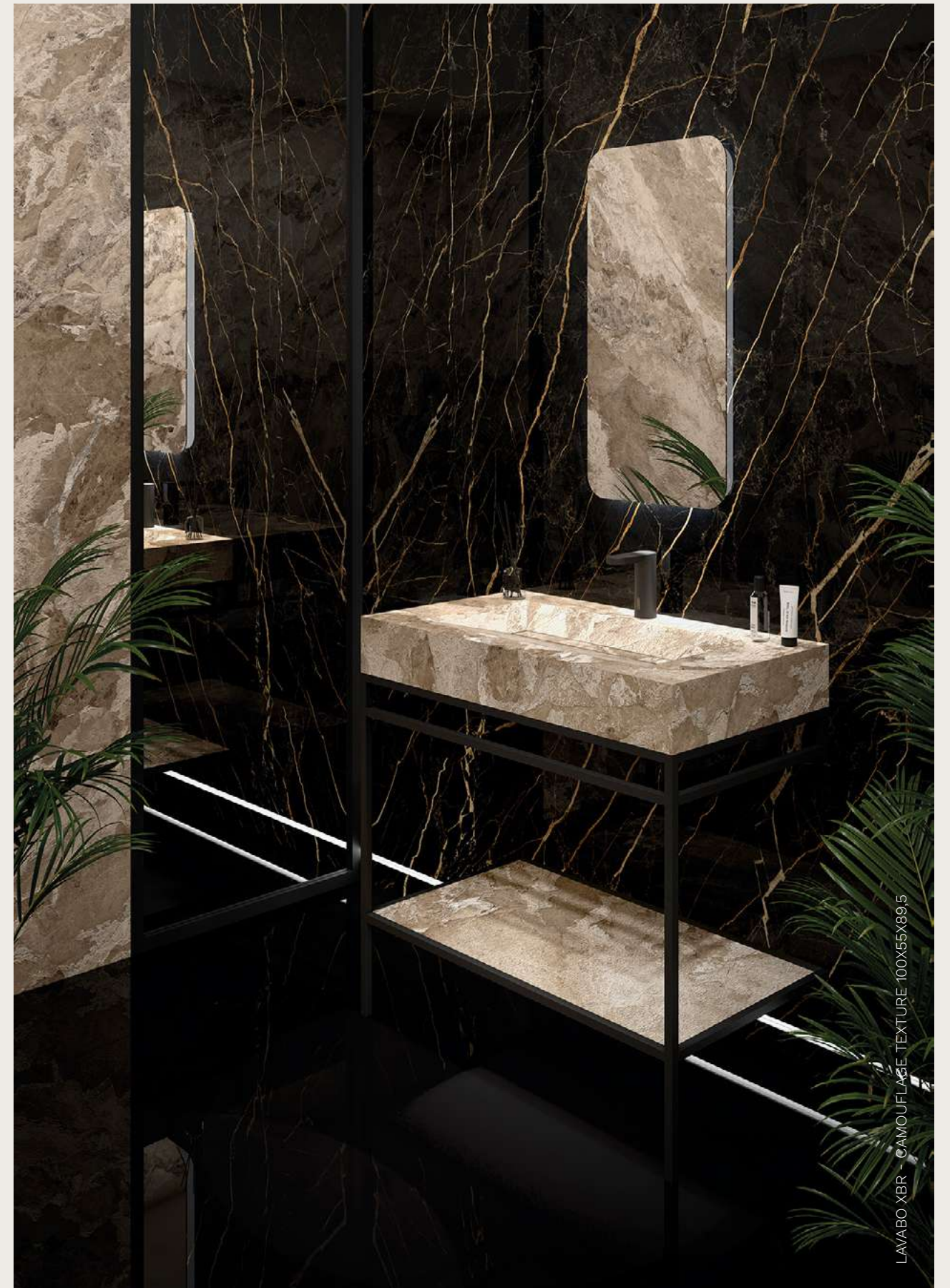







\*Furniture height / Altura del mueble / Hauteur du meuble 76 cm

	Lavabo/Basin			Lavabo/Basin			Lavabo/Basin			Lavabo/Basin		
	Estructura Structure	Nature	Polished	Estructura Structure	Nature	Polished	Estructura Structure	Nature	Polished	Estructura Structure	Nature	Polished
100x55 cm / 39,4" x 21,7"	G1802	G1956		G1801	G1956		G1801	G1956		G1800	G1956	
120x55 cm / 47,2" x 21,7"												
Baldas/Shelves/Étagères												
95,6x50,6 cm / 37,6" x 19,9"		G1800	G1801		G1800	G1801		G1800	G1801		G1800	G1801
115,6x50,6 cm / 45,5" x 19,9"												



LAVABO XBR - CAMOUFLAGE TEXTURE 100X55X89,5

# COLOUR CHART

			TYPOLGY	CONTINUOUS PATTERN	THICKNESS	FINISH	TECHNOLOGY
ANTIQUE GOLD			METAL		6MM · 1/4" 12MM · 1/2"	LAPPATO	TITAN   LUMEN <sup>PREMIUM</sup> Series
ASTANA GREY			MARBLE	I320	6MM · 1/4"	NATURE	LUMEN
				BKM	12MM · 1/2"		
				I320	6MM · 1/4"	POLISHED	-
				BKM	12MM · 1/2"		
AURORA NOIR			MARBLE		6MM · 1/4" 12MM · 1/2"	POLISHED	IRITECH <sup>PREMIUM</sup> Series
BOTANIQUE PRUNE			STONE		6MM · 1/4" 12MM · 1/2"	GLOSSY	-
BOTANIQUE VERT			STONE		6MM · 1/4" 12MM · 1/2"	GLOSSY	-
CALACATTA VIOLA			MARBLE	I320	6MM · 1/4"	NATURE	LUMEN
				I160	12MM · 1/2"		
				I320	6MM · 1/4"	POLISHED	-
				I160	12MM · 1/2"		
CAMOUFLAGE			MARBLE	I320	6MM · 1/4"	TEXTURE	CORE   ECLIPSE
				BKM	12MM · 1/2"		
CEPPO CARABELAS			STONE	I320	6MM · 1/4"	LINES	CORE   LUMEN
				BKM	12MM · 1/2"	TEXTURE	CORE
MALLORCA CALIZA			SANDSTONE		10MM · 3/8"		
				I320	6MM · 1/4"	STRIPED	CORE   LUMEN
					12MM · 1/2"	TEXTURE	CORE
NEGRESKO			MARBLE	C320	6MM · 1/4"	TEXTURE	LUMEN
				BKM	12MM · 1/2"		
STATUARIO VENATO			MARBLE	I320	6MM · 1/4"	NATURE	
				I160	12MM · 1/2"		
				I320	6MM · 1/4"	POLISHED	-
				I160	12MM · 1/2"		
TAJ MAHAL			MARBLE	I320	6MM · 1/4"	NATURE	LUMEN
				BKM	12MM · 1/2"		
				I320	6MM · 1/4"	POLISHED	-
				BKM	12MM · 1/2"		
				I320	6MM · 1/4"		
				BKM	12MM · 1/2"	SILK	
				BKM	20MM · 3/4"		

**COMMITMENT WITH THE ENVIRONMENT.** All our products are manufactured with at least 40% recycled material, contributing to the realization of sustainable and self-sufficient projects from an energetic point of view and hit the requirements of LEED certification (Leadership in Energy and Environmental Design) and BREEAM (Building Research Establishment Environmental Assessment Method) in recycled material content, without VOC emissions and 100% recyclable reuse. XTONE products have a low environmental impact throughout their entire life cycle.

**COMPROMISO CON EL MEDIOAMBIENTE.** Todos los productos están fabricados con al menos un 40% de material reciclado, contribuyendo a la realización de proyectos sostenibles y autosuficientes a nivel energético y al alcance de los créditos LEED (Liderazgo en Energía y Diseño Medioambiental) o BREEAM (Método de Evaluación Medioambiental del Organismo de Investigación de la Construcción) en contenido de material reciclado, sin emisiones COV y de reutilización 100% reciclable. Los productos XTONE generan un bajo impacto ambiental durante todo su ciclo de vida.

**ENGAGEMENT ENVERS L'ENVIRONNEMENT.** Tous les produits sont fabriqués avec au moins 40% de matériaux recyclés, contribuant à la réalisation de projets durables et autonomes au niveau énergétique et à la portée des crédits LEED (Leadership en Energie et Design Environnemental) ou BREEAM (Méthode d'évaluation environnementale de l'Agence de recherche en construction) en teneur en matériaux recyclés, sans émissions de COV et de réutilisation 100% recyclable. Les produits XTONE ont une faible incidence sur l'environnement tout au long de leur cycle de vie.



PORCELANOSA, S.A. reserves the right to modify and/or discontinue certain models displayed in this catalogue. The colours and finishes of tiles shown in the catalogue may differ slightly from the originals. The settings shown in this catalogue are design proposals for advertising purposes. In real situations in which the tiles are laid, the installation instructions published by PORCELANOSA should be followed. It is agreed that weights, dimensions, capacities, prices, performances, colours and other data contained in catalogues, prospectuses, circulars, illustrations, price-lists or other illustrative seller's documents, shall all constitute an approximate guide only.

PORCELANOSA, S.A. se reserva el derecho de modificar y/o suprimir ciertos modelos expuestos en este catálogo sin previo aviso. Los colores y acabados de las piezas pueden presentar ligeras diferencias respecto a los originales. Los ambientes que se muestran en este catálogo son sugerencias decorativas de carácter publicitario debiéndose utilizar en la instalación real las instrucciones de colocación editadas por PORCELANOSA. Los pesos, las dimensiones, las capacidades, los precios, los rendimientos, los colores y otros datos que figuren en los catálogos, prospectos, circulares, ilustraciones, listines de precios u otros documentos ilustrativos del vendedor, tienen carácter de indicaciones aproximativas.

*PORCELANOSA, S.A. se réserve le droit de modifier et supprimer certains modèles exposés dans ce catalogue sans avertir préalablement. Les couleurs et finitions des pièces peuvent présenter légères différences par rapport aux originaux. Les ambiances montrées dans ce catalogue sont des suggestions décoratives de caractère publicitaire, devant utiliser les instructions de pose recommandées par PORCELANOSA pour son installation réelle. Les poids, les dimensions, les capacités, les prix, les rendements, les couleurs et autres données contenues dans les catalogues, brochures, bulletins, des illustrations, liste de prix et d'autres documents illustratifs du vendeur, ont caractère d'indication approximative.*

**NEW COLLECTION  
MOSTRA 2026. ED1**

© 2026 PORCELANOSA, S.A.

Ctra. N-340 Km 56,2  
CP 12540 Vila-real, Castellón, ESPAÑA  
Tel. (+34) 964 52 52 00 | info@xtone-surface.com  
www.xtone-surface.com



FS10/7955



FS10/7954



BY APPOINTMENT TO  
H.M. THE KING  
MANUFACTURERS AND DISTRIBUTORS  
OF CERAMIC TILES AND BUILDING PRODUCTS.  
PORCELANOSA UK LIMITED

**PORCELANOSA** Grupo